

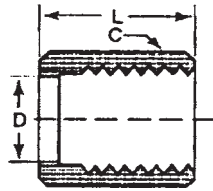

Stems for SAE 100R1, 100R1AT, 100R2, 100R2AT, 100R3, 100R4, 100R5, Hydra-Lite I & II

NUT FOR MALE FLARELESS STEM AND STAND PIPE



Part Number	Tube O.D.	Thread	Hex	Length
E04-N	1/4	7/16 - 20	9/16	.700
E05-N	5/16	1/2 - 20	5/8	.720
E06-N	3/8	9/16 - 18	11/16	.750
E08-N	1/2	3/4 - 16	7/8	.840
E10-N	5/8	7/8 - 14	1	.920
E12-N	3/4	1-1/16 - 12	1-1/4	.970
E16-N	1	1-5/16 - 12	1-3/8	1.050
E20-N	1-1/4	1-5/8 - 12	2	1.050

SLEEVE FOR MALE FLARELESS STEM AND STAND PIPE

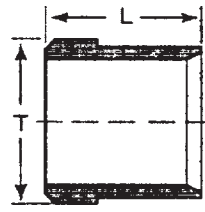

Part Number	Tube O.D.	Sleeve O.D.	Length
E04-S	1/4	.370	.360
E05-S	5/16	.420	.340
E06-S	3/8	.500	.390
E08-S	1/2	.660	.430
E10-S	5/8	.780	.440
E12-S	3/4	.930	.480
E16-S	1	1.190	.480
E20-S	1-1/4	1.450	.480

INCH STAND PIPE

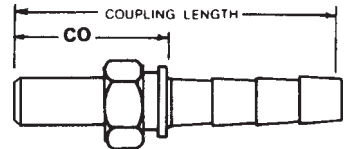

Part Number	Hose I.D.	Tube O.D.	Tube Length	Fitting Length	-CO-Cutoff
204-ST-4	1/4	1/4	.750	2.222	1.312
204-ST-6	1/4	3/8	.875	2.347	1.437
205-ST-6	5/16	3/8	.875	2.347	1.437
406-ST-6	3/8	3/8	.875	2.472	1.562
406-ST-8	3/8	1/2	1.000	2.597	1.687
408-ST-8	1/2	1/2	1.000	2.847	1.687
408-ST-10	1/2	5/8	1.000	2.847	1.687
410-ST-12	5/8	3/4	1.125	3.003	1.843
412-ST-12	3/4	3/4	1.125	3.691	1.836
416-ST-16	1	1	1.250	4.050	2.000

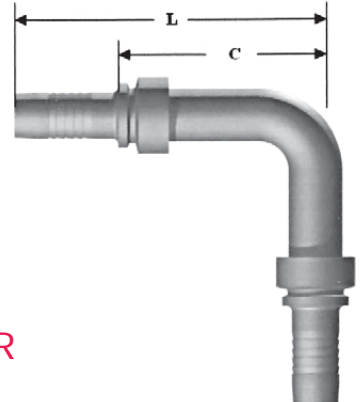

LENGTH EXTENDER 90° BENT TUBE

Part Number	Hose I.D.	Tubing	Tube Length	-C-Cutoff	Tube Steel
• 206-90-T06	3/8	3/8 +.065W	3.070	1.91	206-T06
• 208-90-T08	1/2	1/2 +.095W	3.070	2.38	208-T08
• 412-90-T12	3/4	3/8 +.109W	4.235	2.76	412-T12
• 416-90-T16	1	1 +.120W	4.810	3.30	416-T16
• 420-90-T20	1-1/4	1-1/4 +.120W	5.180	2.16	420-T20

TUBE STEM

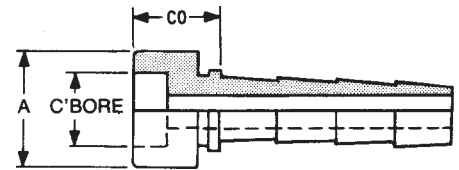

Part Number	Hose I.D.	C'Bore DIA	C'Bore Depth	-A-O.D.	Stem I.D.	Fitting Length	-CO-Cutoff
203-T03	3/16	3/16	.218	1/2	.125	1.390	.515
203-T04	3/16	1/4	.218	1/2	.125	1.390	.515
203-T05	3/16	5/16	.218	1/2	.125	1.390	.515
204-T03	1/4	3/16	.218	.604	.156	1.472	.562
204-T04	1/4	1/4	.218	.604	.156	1.472	.562
204-T05	1/4	5/16	.218	.604	.156	1.472	.562
204-T06	1/4	3/8	.218	.604	.156	1.472	.562
205-T04	5/16	1/4	.218	.604	.234	1.472	.562
205-T05	5/16	5/16	.218	.604	.234	1.472	.562
205-T06	5/16	3/8	.218	.604	.234	1.472	.562
206-T04	3/8	1/4	.218	3/4	.296	1.472	.562
206-T05	3/8	5/16	.218	3/4	.296	1.472	.562
206-T06	3/8	3/8	.218	3/4	.296	1.472	.562
206-T08	3/8	1/2	.218	3/4	.296	1.472	.562
206-T10	3/8	5/8	.218	1-3/16	.296	1.472	.562
208-T06	1/2	3/8	.218	7/8	.359	1.723	.562
208-T08	1/2	1/2	.218	7/8	.406	1.723	.562
208-T10	1/2	5/8	.218	1	.406	1.723	.562
208-T12	1/2	3/4	.218	1	.406	1.723	.562
210-T08	5/8	1/2	.312	1	.466	1.890	.734
210-T10	5/8	5/8	.312	1	.500	1.890	.734
210-T12	5/8	3/4	.312	1	.500	1.890	.734
212-T10	3/4	5/8	.375	1-3/16	.625	2.005	.755
212-T12	3/4	3/4	.375	1-3/16	.625	2.005	.755
212-T14	3/4	7/8	.375	1-3/16	.625	2.005	.755
212-T16	3/4	1	.375	1-3/16	.625	2.005	.755
214-T16	7/8	1	.375	1-3/16	.671	2.005	.755
216-T12	1	3/4	.375	1-1/2	.734	2.235	.765
216-T16	1	1	.375	1-1/2	.843	2.235	.765
420-T20	1-1/4	1-1/4	.375	1-7/16	1.062	2.840	1.920
420-T24	1-1/4	1-1/2	.375	1-3/4	1.062	2.840	1.920
424-T20	1-1/2	1-1/4	.375	1-13/16	1.234	3.562	2.659
424-T24	1-1/2	1-1/2	.375	1-13/16	1.250	3.258	2.338
424-T32	1-1/2	2	.375	2-1/4	1.250	3.258	2.338
432-T32	2	2	.375	2-1/4	1.655	4.086	3.167

• Indicates change or new product

British Standard and Metric Stems



BRITISH STANDARD TAPERED PIPE BSPT SOLID MALE STEM 30° SEAT

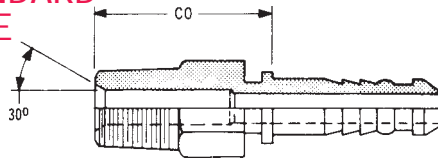

Part Number	Hose I.D.	Thread	Hex	Fitting Length	-CO-Cutoff
204-BT-104	1/4	1/4-19	5/8	1.875	.965
204-BT-106	1/4	3/8-19	11/16	1.875	.965
206-BT-106	3/8	3/8-19	11/16	1.906	.996
208-BT-108	1/2	1/2-14	7/8	2.316	1.156
412-BT-112	3/4	3/4-14	1-1/16	3.197	1.342
416-BT-116	1	1-11	1-3/8	3.603	1.553

KOMATSU SWIVEL FEMALE STEM 30° SEAT

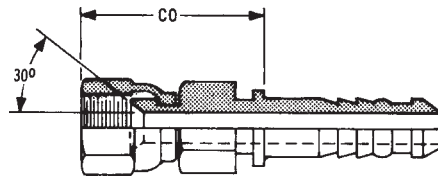

Part Number	Hose I.D.	Thread	Nut Hex	Stem Hex	Fitting Length	-CO-Cutoff
204-KU-614	1/4	14MM X 1.5	3/4	5/8	2.035	1.125
204-KU-618	1/4	18MM X 1.5	7/8	11/16	2.158	1.248
206-KU-618	3/8	18MM X 1.5	7/8	11/16	2.158	1.248
208-KU-622	1/2	22MM X 1.5	1-1/16	13/16	2.545	1.385
208-KU-624	1/2	24MM X 1.5	1-1/4	1	2.631	1.471
210-KU-624	5/8	24MM X 1.5	1-1/4	1	2.662	1.502
412-KU-630	3/4	30MM X 1.5	1-1/2	1-1/4	3.584	1.729
416-KU-633	1	33MM X 1.5	1-5/8	1-3/8	3.805	1.755
220-KU-636	1-1/4	36MM X 1.5	1-3/4	1-3/4	4.198	2.276
224-KU-642	1-1/2	42MM X 1.5	2-1/4	2	4.795	2.457

SOLID MALE STEM DIN 20078 LIGHT 12° SEAT

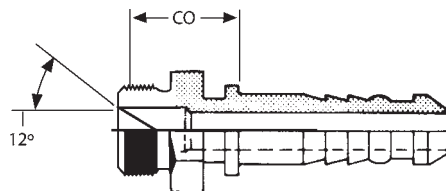

Part Number	Hose I.D.	Thread	Hex	Fitting Length	-CO-Cutoff
204-DL-112	1/4	12MM X 1.5	1/2	1.793	.883
204-DL-114	1/4	14MM X 1.5	5/8	1.793	.883
204-DL-116	1/4	16MM X 1.5	11/16	1.793	.883
206-DL-116	3/8	16MM X 1.5	11/16	1.824	.914
206-DL-118	3/8	18MM X 1.5	3/4	1.824	.914
206-DL-122	3/8	22MM X 1.5	7/8	1.910	1.000
208-DL-122	1/2	22MM X 1.5	7/8	2.222	1.062
208-DL-126	1/2	26MM X 1.5	1-1/16	2.222	1.062
210-DL-126	5/8	26MM X 1.5	1-1/16	2.253	1.093
412-DL-126	3/4	26MM X 1.5	1-1/16	3.031	1.176
412-DL-130	3/4	30MM X 2	1-1/4	3.081	1.226
412-DL-136	3/4	36MM X 2	1-1/2	3.231	1.376
416-DL-136	1	36MM X 2	1-1/2	3.515	1.465

METRIC STAND PIPE

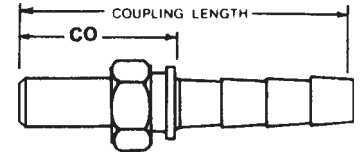

Part Number	Hose I.D.	Din Tube O.D. (MM)	Tube Length	Fitting Length	-CO-Cutoff
204-ST-6M	1/4	6	.750	2.187	1.312
204-ST-8M	1/4	8	.875	2.312	1.437
204-ST-10M	1/4	10	.875		
205-ST-8M	5/16	8	.875	2.312	1.437
205-ST-10M	5/16	10	.875		
406-ST-10M	3/8	10	.875	2.472	1.562
406-ST-12M	3/8	12	1.000	2.597	1.687
406-ST-14M	3/8	14	1.000		
408-ST-15M	1/2	15	1.000	2.847	1.687
408-ST-16M	1/2	16	1.000	2.847	1.687
408-ST-18M	1/2	18	1.125		
410-ST-18M	5/8	18	1.125	3.003	1.843
410-ST-20M	5/8	20	1.125		
412-ST-20M	3/4	20	1.125	3.691	1.836
412-ST-22M	3/4	22	1.250		
412-ST-25M	3/4	25	1.250		
416-ST-25M	1	25	1.250	4.050	2.000
416-ST-28M	1	28	1.250		
416-ST-30M	1	30	1.250		

METRIC TUBE NUT

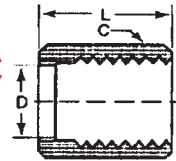

METRIC SLEEVE

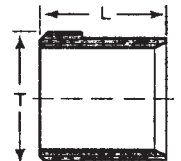

Tube Nut - Light Part Number	Thread	Din Tube O.D. (MM)	Sleeve - Light Part Number
9201-L-6	12MM x 1.5	6	9202-L-6
9201-L-8	14MM x 1.5	8	9202-L-8
9201-L-10	16MM x 1.5	10	9202-L-10
9201-L-12	18MM x 1.5	12	9202-L-12
9201-L-15	22MM x 1.5	15	9202-L-15
9201-L-18	26MM x 1.5	18	9202-L-18
9201-L-22	30MM x 2	22	9202-L-22
9201-L-28	36MM x 2	28	9202-L-28
9201-L-35	45MM x 2	35	9202-L-35
9201-L-42	52MM x 2	42	9202-L-42

Tube Nut - Heavy Part Number	Thread	Din Tube O.D. (MM)	Sleeve - Heavy Part Number
9201-H-6	14MM x 1.5	6	9202-H-6
9201-H-8	16MM x 1.5	8	9202-H-8
9201-H-10	18MM x 1.5	10	9202-H-10
9201-H-12	20MM x 1.5	12	9202-H-12
9201-H-14	22MM x 1.5	14	9202-H-14
9201-H-16	24MM x 1.5	16	9202-H-16
9201-H-20	30MM x 2	20	9202-H-20
9201-H-25	36MM x 2	25	9202-H-25
9201-H-30	42MM x 2	30	9202-H-30
9201-H-38	52MM x 2	38	9202-H-38

One-Piece Bite the Wire Fittings for SAE 100R1AT, 100R2AT, 100R5, 100R16, 100R17, Hydra-Lite I & II, and Hydra-Max



SWIVEL FEMALE FLARELESS 24° CONE

For Flareless Sleeve and Nut

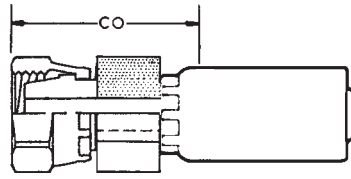

Part Number	Hose I.D.	Thread	Stem Hex	Nut Hex	Stem I.D.	Fitting Length	-CO-Cutoff
204-1JMFx-4	1/4	7/16-20	5/8	9/16	.156	2.122	1.237
204-1JMFx-5	1/4	1/2-20	5/8	11/16	.156		
206-1JMFx-6	3/8	9/16-18	11/16	3/4	.296		
206-1JMFx-8	3/8	3/4-16	11/16	7/8	.296		
208-1JMFx-8	1/2	3/4-16	13/16	7/8	.406		
208-1JMFx-10	1/2	7/8-14	13/16	1-1/16	.406		
208-1JMFx-11	1/2	15/16-16	1	1-1/8	.406		
212-1JMFx-12	3/4	1-1/16-12	1-1/16	1-1/4	.625	3.017	1.777
216-1JMFx-16	1	1-5/16-12	1-3/8	1-1/2	.844	3.487	2.032
216-1JMFxSP-16	1	1-5/16-16	1-3/8	1-1/2	.844	3.487	2.032
220-1JMFx-20	1-1/4	1-5/8-12	1-3/4	2	1.062		

SAE 45° SWIVEL FEMALE STEM 90° BENT TUBE SHORT DROP

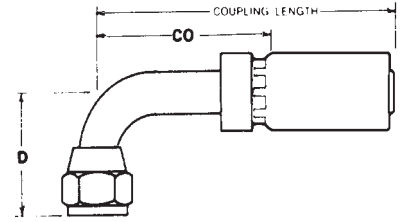

Part Number	Hose I.D.	Thread	Nut Hex	-D-Drop	Fitting Length	-CO-Cutoff
206-1JS-466	3/8	5/8-18	3/4	.850	2.575	1.665
206-1JS-468	3/8	3/4-16	7/8	1.170	2.670	1.760
208-1JS-468	1/2	3/4-16	7/8	1.090	2.780	1.620

INCH STAND PIPE

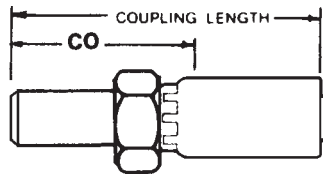

Part Number	Hose I.D.	Tube O.D.	Tube Length	Fitting Length	-CO-Cutoff
204-1JST-4	1/4	1/4	.750	2.222	1.312
204-1JST-6	1/4	3/8	.875	2.347	1.437
406-1JST-6	3/8	3/8	.875	2.472	1.562
406-1JST-8	3/8	1/2	1.000	2.597	1.687
408-1JST-8	1/2	1/2	1.000	2.847	1.687
408-1JST-10	1/2	5/8	1.000	2.847	1.687
410-1JST-12	5/8	3/4	1.125	3.003	1.843
412-1JST-12	3/4	3/4	1.125	3.691	1.836
416-1JST-16	1	1	1.250	4.050	2.000

SAE 45° SWIVEL FEMALE 90° BENT TUBE MEDIUM DROP

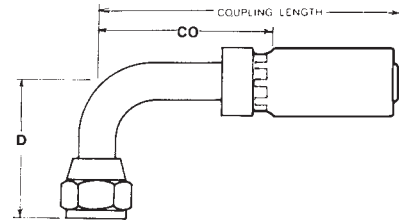

Part Number	Hose I.D.	Thread	Nut Hex	-D-Drop	Fitting Length	-CO-Cutoff
204-1JM-464	1/4	7/16-20	9/16	.880	2.335	1.425
206-1JM-466	3/8	5/8-18	3/4	1.160	2.675	1.765

SAE 45° SWIVEL FEMALE 45° BENT TUBE SHORT DROP

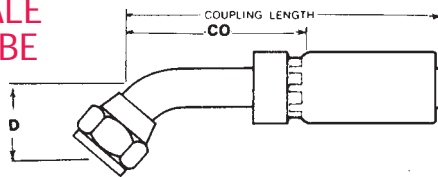

Part Number	Hose I.D.	Thread	Nut Hex	-D-Drop	Fitting Length	-CO-Cutoff
206-1JS-486	3/8	5/8-18	3/4	.410	2.925	2.015
206-1JS-488	3/8	3/4-16	7/8	.550	3.285	2.365

JIC 37° SWIVEL FEMALE STEM 45° BENT TUBE SHORT DROP

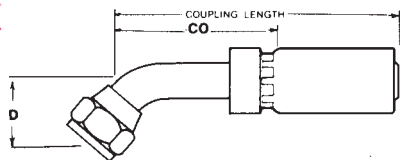

Part Number	Hose I.D.	Thread	Hex	-D-Drop	Fitting Length	-CO-Cutoff
204-1JS-684	1/4	7/16-20	9/16	.330	2.605	1.695
204-1JS-685	1/4	1/2-20	5/8	.360	2.705	1.795
204-1JS-686	1/4	9/16-18	11/16	.410	2.925	2.010
206-1JS-686	3/8	9/16-18	11/16	.410	2.925	2.015
206-1JS-688	3/8	3/4-16	7/8	.550	3.275	2.240
208-1JS-688	1/2	3/4-16	7/8	.550	3.463	2.303
208-1JS-690	1/2	7/8-14	1	.650	3.763	2.603
210-1JS-690	5/8	7/8-14	1	.650	3.785	2.620
210-1JS-692	5/8	1-1/16 - 12	1-1/4	.780	4.045	2.885
212-1JS-692	3/4	1-1/16 - 12	1-1/4	.780	4.145	2.895
212-1JS-694	3/4	1-3/16 - 12	1-3/8	.860	4.405	3.150
212-1JS-696	3/4	1-5/16 - 12	1-1/2	.890	4.555	3.300
216-1JS-692	1	1-1/16 - 12	1-1/4	.780	4.430	2.960
216-1JS-696	1	1-5/16 - 12	1-1/2	.890	4.430	2.960



1J

One-Piece Bite the Wire British Standard Fittings for SAE 100R1AT, 100R2AT, 100R5, 100R16, 100R17, Hydra-Lite I & II, and Hydra-Max

BRITISH STANDARD TAPERED PIPE BSPT SOLID MALE STEM 30° SEAT

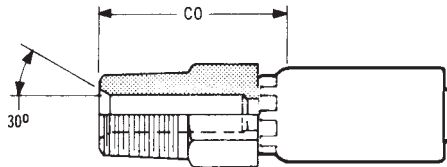

Part Number	Hose I.D.	Thread	Hex	Fitting Length	-CO-Cutoff
204-1JBT-104	1/4	1/4-19	5/8	1.875	.965
204-1JBT-106	1/4	3/8-19	11/16	1.875	.965
206-1JBT-106	3/8	3/8-19	11/16	1.906	.996
208-1JBT-108	1/2	1/2-14	7/8	2.316	1.156
412-1JBT-112	3/4	3/4-14	1-1/16	3.197	1.342
416-1JBT-116	1	1-11	1-3/8	3.603	1.553

KOMATSU SWIVEL FEMALE STEM 30° SEAT

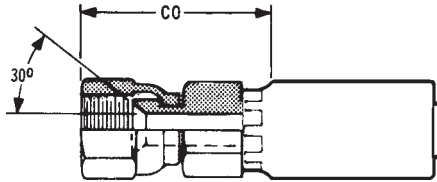

Part Number	Hose I.D.	Thread	Nut Hex	Stem Hex	Fitting Length	-CO-Cutoff
204-1JKU-614	1/4	14MM X 1.5	3/4	5/8	2.035	1.125
204-1JKU-618	1/4	18MM X 1.5	7/8	11/16	2.158	1.248
206-1JKU-618	3/8	18MM X 1.5	7/8	11/16	2.158	1.248
208-1JKU-622	1/2	22MM X 1.5	1-1/16	13/16	2.545	1.385
208-1JKU-624	1/2	24MM X 1.5	1-1/4	1	2.631	1.471
210-1JKU-624	5/8	24MM X 1.5	1-1/4	1	2.662	1.502
412-1JKU-630	3/4	30MM X 1.5	1-1/2	1-1/4	3.584	1.729
416-1JKU-633	1	33MM X 1.5	1-5/8	1-3/8	3.805	1.755
220-1JKU-636	1-1/4	36MM X 1.5	1-3/4	1-3/4	4.198	2.276
224-1JKU-642	1-1/2	42MM X 1.5	2-1/4	2	4.795	2.457

SOLID MALE STEM DIN 20078 LIGHT 12° SEAT

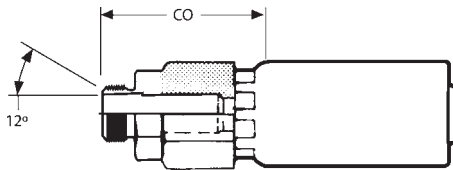

Part Number	Hose I.D.	Thread	Hex	Fitting Length	-CO-Cutoff
204-1JDL-112	1/4	12MM X 1.5	1/2	1.793	.883
204-1JDL-114	1/4	14MM X 1.5	5/8	1.793	.883
204-1JDL-116	1/4	16MM X 1.5	11/16	1.793	.883
206-1JDL-116	3/8	16MM X 1.5	11/16	1.824	.914
206-1JDL-118	3/8	18MM X 1.5	3/4	1.824	.914
206-1JDL-122	3/8	22MM X 1.5	7/8	1.910	1.000
208-1JDL-122	1/2	22MM X 1.5	7/8	2.222	1.062
208-1JDL-126	1/2	26MM X 1.5	1-1/16	2.222	1.062
210-1JDL-126	5/8	26MM X 1.5	1-1/16	2.253	1.093
412-1JDL-126	3/4	26MM X 1.5	1-1/16	3.031	1.176
412-1JDL-130	3/4	30MM X 2	1-1/4	3.081	1.226
412-1JDL-136	3/4	36MM X 2	1-1/2	3.231	1.376
416-1JDL-136	1	36MM X 2	1-1/2	3.515	1.465

METRIC STAND PIPE

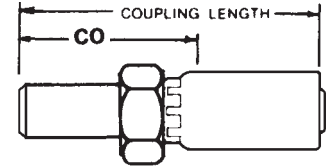

Part Number	Hose I.D.	Din Tube O.D. (MM)	Tube Length	Fitting Length	-CO-Cutoff
204-1JST-6M	1/4	6	.750	2.187	1.312
204-1JST-8M	1/4	8	.875	2.312	1.437
204-1JST-10M	1/4	10	.875		
406-1JST-10M	3/8	10	.875	2.472	1.562
406-1JST-12M	3/8	12	1.000	2.597	1.687
406-1JST-14M	3/8	14	1.000		
408-1JST-15M	1/2	15	1.000	2.847	1.687
408-1JST-16M	1/2	16	1.000	2.847	1.687
408-1JST-18M	1/2	18	1.125		
410-1JST-18M	5/8	18	1.125	3.003	1.843
410-1JST-20M	5/8	20	1.125		
412-1JST-20M	3/4	20	1.125	3.691	1.836
412-1JST-22M	3/4	22	1.250		
412-1JST-25M	3/4	25	1.250		
416-1JST-25M	1	25	1.250	4.050	2.000
416-1JST-28M	1	28	1.250		
416-1JST-30M	1	30	1.250		

METRIC SWIVEL FEMALE STEM DIN 20078 LIGHT STRAIGHT W/O-RING

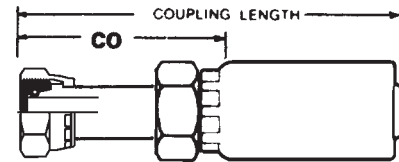

Part Number	Hose I.D.	Thread	DIN Tube O.D.(mm)	Nut Hex (mm)	Fitting Length	-CO-Cutoff
204-1JDL-612	1/4	12MM X 1.5	6	17	1.850	.940
204-1JDL-614	1/4	14MM X 1.5	8	17	1.811	.901
204-1JDL-616	1/4	16MM X 1.5	10	19	1.831	.921
206-1JDL-616	3/8	16MM X 1.5	10	19	1.831	.921
206-1JDL-618	3/8	18MM X 1.5	12	22	1.870	.960
206-1JDL-622	3/8	22MM X 1.5	15	27	2.008	1.098
208-1JDL-622	1/2	22MM X 1.5	15	27	2.244	1.084
210-1JDL-626	5/8	26MM X 1.5	18	32	2.264	1.104

METRIC SWIVEL FEMALE STEM DIN 20078 LIGHT 45° BENT TUBE W/O-RING

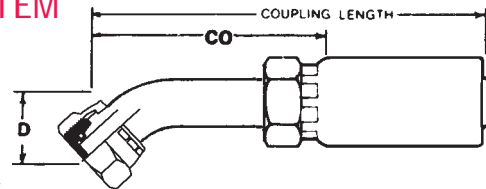

Part Number	Hose I.D.	Thread	DIN Tube O.D.(mm)	Nut Hex (mm)	-D-Drop	Fitting Length	-CO-Cutoff
204-1JDL-614 45	1/4	14MM X 1.5	8	17	.748	2.402	1.492
204-1JDL-616 45	1/4	16MM X 1.5	10	19	.748	2.402	1.492
206-1JDL-616 45	3/8	16MM X 1.5	10	19	.827	2.638	1.728
206-1JDL-618 45	3/8	18MM X 1.5	12	22	.846	2.677	1.767
208-1JDL-622 45	1/2	22MM X 1.5	15	27	.984	3.189	2.029
210-1JDL-626 45	5/8	26MM X 1.5	18	32	1.063	3.445	2.285

One-Piece Compression Fittings for SAE 100R1, 100R7, 100R8



MALE FLARELESS STEM

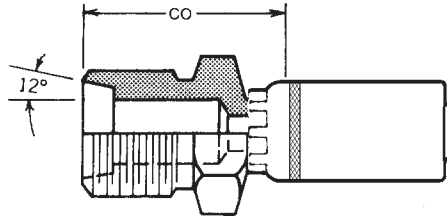

Part Number	Hose I.D.	Thread	Hex	Stem I.D.	Fitting Length	-CO-Cutoff
204-1P-E04	1/4	7/16-20	5/8	.156	1.831	.921
204-1P-E06	1/4	9/16-18	5/8	.156	1.847	.937
206-1P-E05	3/8	1/2-20	11/16	.234	1.863	.953
206-1P-E06	3/8	9/16-18	11/16	.296	1.879	.969
206-1P-E08	3/8	3/4-16	13/16	.296	1.971	1.061
208-1P-E08	1/2	3/4-16	13/16	.406	2.285	1.125
208-1P-E10	1/2	7/8-14	1	.406	2.348	1.188

SWIVEL FEMALE FLARELESS 24° CONE

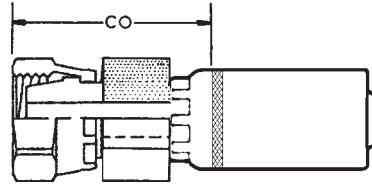

For Flareless Sleeve and Nut

Part Number	Hose I.D.	Thread	Stem Hex	Nut Hex	Stem I.D.	Fitting Length	-CO-Cutoff
204-1PMFX-4	1/4	7/16-20	5/8	9/16	.156	2.122	1.237
204-1PMFX-5	1/4	1/2-20	5/8	11/16	.156		
206-1PMFX-6	3/8	9/16-18	11/16	3/4	.296		
206-1PMFX-8	3/8	3/4-16	11/16	7/8	.296		
208-1PMFX-8	1/2	3/4-16	13/16	7/8	.406		
208-1PMFX-10	1/2	7/8-14	13/16	1-1/16	.406		
208-1PMFX-11	1/2	15/16-16	1	1-1/8	.406		
212-1PMFX-12	3/4	1-1/16-12	1-1/16	1-1/4	.625	3.017	1.777
216-1PMFX-16	1	1-5/16-12	1-3/8	1-1/2	.844	3.487	2.032
216-1PMFXSP-16	1	1-5/16-16	1-3/8	1-1/2	.844	3.487	2.032

INCH STAND PIPE

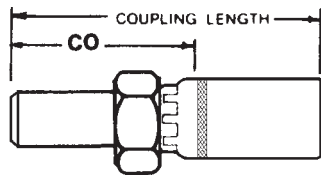

Part Number	Hose I.D.	Tube O.D.	Tube Length	Fitting Length	-CO-Cutoff
204-1PST-4	1/4	1/4	.750	2.222	1.312
204-1PST-6	1/4	3/8	.875	2.347	1.437
406-1PST-6	3/8	3/8	.875	2.472	1.562
406-1PST-8	3/8	1/2	1.000	2.597	1.687
408-1PST-8	1/2	1/2	1.000	2.847	1.687
408-1PST-10	1/2	5/8	1.000	2.847	1.687
410-1PST-12	5/8	3/4	1.125	3.003	1.843
412-1PST-12	3/4	3/4	1.125	3.691	1.836
416-1PST-16	1	1	1.250	4.050	2.000

SAE 45° SWIVEL FEMALE ONE-PIECE 45° BENT TUBE SHORT DROP

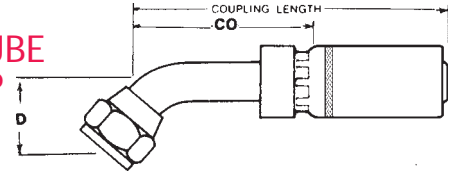

Part Number	Hose I.D.	Thread	Nut Hex	-D-Drop	Fitting Length	-CO-Cutoff
206-1PS-486	3/8	5/16-18	3/4	.410	2.925	2.015
206-1PS-488	3/8	3/4-16	7/8	.550	3.285	2.365

SAE 45° SWIVEL FEMALE STEM 90° BENT TUBE SHORT DROP

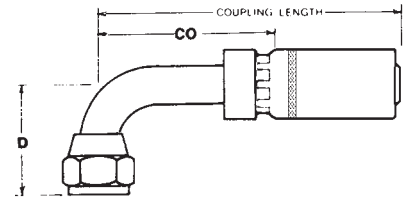

Part Number	Hose I.D.	Thread	Nut Hex	-D-Drop	Fitting Length	-CO-Cutoff
206-1PS-466	3/8	5/8-18	3/4	.850	2.575	1.665
206-1PS-468	3/8	3/4-16	7/8	1.170	2.670	1.760
208-1PS-468	1/2	3/4-16	7/8	1.090	2.780	1.620

SAE 45° SWIVEL FEMALE ONE-PIECE 90° BENT TUBE MEDIUM DROP

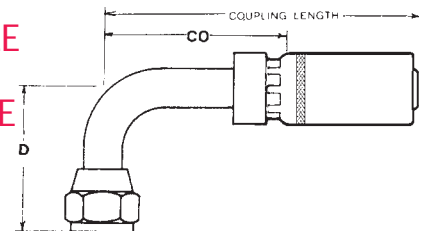

Part Number	Hose I.D.	Thread	Nut Hex	-D-Drop	Fitting Length	-CO-Cutoff
204-1PM-464	1/4	7/16-20	9/16	.880	2.335	1.425
206-1PM-466	3/8	5/8-18	3/4	1.160	2.675	1.765



1P

One-Piece British Standard and Metric Fittings for SAE 100R1, 100R7, 100R8

BRITISH STANDARD TAPERED PIPE BSPT SOLID MALE STEM 30° SEAT

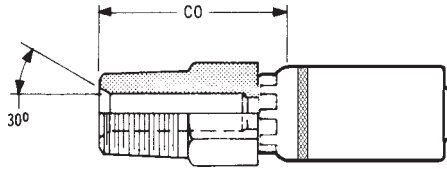

Part Number	Hose I.D.	Thread	Hex	Fitting Length	-CO-Cutoff
204-1PBT-104	1/4	1/4-19	5/8	1.875	.965
204-1PBT-106	1/4	3/8-19	11/16	1.875	.965
206-1PBT-106	3/8	3/8-19	11/16	1.906	.996
208-1PBT-108	1/2	1/2-14	7/8	2.316	1.156
412-1PBT-112	3/4	3/4-14	1-1/16	3.197	1.342
416-1PBT-116	1	1-11	1-3/8	3.603	1.553

KOMATSU SWIVEL FEMALE STEM 30° SEAT

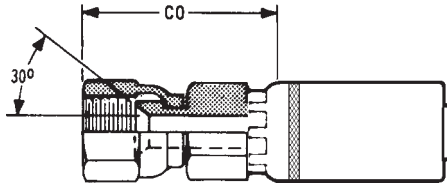

Part Number	Hose I.D.	Thread	Nut Hex	Stem Hex	Fitting Length	-CO-Cutoff
204-1PKU-614	1/4	14MM x 1.5	3/4	5/8	2.035	1.125
204-1PKU-618	1/4	18MM x 1.5	7/8	11/16	2.158	1.248
206-1PKU-618	3/8	18MM x 1.5	7/8	11/16	2.158	1.248
208-1PKU-622	1/2	22MM x 1.5	1-1/16	13/16	2.545	1.385
208-1PKU-624	1/2	24MM x 1.5	1-1/4	1	2.631	1.471
412-1PKU-630	3/4	30MM x 1.5	1-1/2	1-1/4	3.584	1.729
416-1PKU-633	1	33MM x 1.5	1-5/8	1-3/8	3.805	1.755

SOLID MALE STEM DIN 20078 LIGHT 12° SEAT

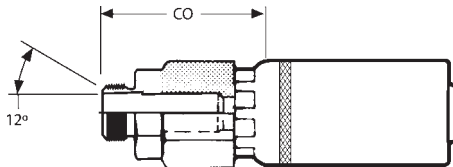

Part Number	Hose I.D.	Thread	Hex	Fitting Length	-CO-Cutoff
204-1PDL-112	1/4	12MM x 1.5	1/2	1.793	.883
204-1PDL-114	1/4	14MM x 1.5	5/8	1.793	.883
204-1PDL-116	1/4	16MM x 1.5	11/16	1.793	.883
206-1PDL-116	3/8	16MM x 1.5	11/16	1.824	.914
206-1PDL-118	3/8	18MM x 1.5	3/4	1.824	.914
206-1PDL-122	3/8	22MM x 1.5	7/8	1.910	1.000
208-1PDL-122	1/2	22MM x 1.5	7/8	2.222	1.062
208-1PDL-126	1/2	26MM x 1.5	1-1/16	2.222	1.062
412-1PDL-126	3/4	26MM x 1.5	1-1/16	3.031	1.176
412-1PDL-130	3/4	30MM x 2	1-1/4	3.081	1.226
412-1PDL-136	3/4	36MM x 2	1-1/2	3.231	1.376
416-1PDL-136	1	36MM x 2	1-1/2	3.515	1.465

METRIC STAND PIPE

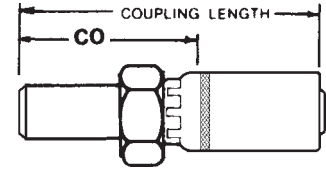

Part Number	Hose I.D.	Din Tube O.D. (MM)	Tube Length	Fitting Length	-CO-Cutoff
204-1PST-6M	1/4	6	.750	2.187	1.312
204-1PST-8M	1/4	8	.875	2.312	1.437
204-1PST-10M	1/4	10	.875		
406-1PST-10M	3/8	10	.875	2.472	1.562
406-1PST-12M	3/8	12	1.000	2.597	1.687
406-1PST-14M	3/8	14	1.000		
408-1PST-15M	1/2	15	1.000	2.847	1.687
408-1PST-16M	1/2	16	1.000	2.847	1.687
408-1PST-18M	1/2	18	1.125		
412-1PST-20M	3/4	20	1.125	3.691	1.836
412-1PST-22M	3/4	22	1.250		
412-1PST-25M	3/4	25	1.250		
416-1PST-25M	1	25	1.250	4.050	2.000
416-1PST-28M	1	28	1.250		
416-1PST-30M	1	30	1.250		

METRIC SWIVEL FEMALE STEM DIN 20078 LIGHT STRAIGHT W/O-RING

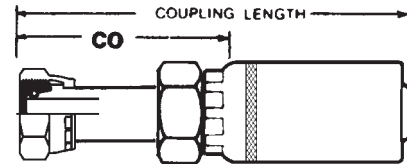

Part Number	Hose I.D.	Thread	DIN Tube O.D.(mm)	Nut Hex (mm)	Fitting Length	-CO-Cutoff
204-1PDL-612	1/4	12MM x 1.5	6	17	1.850	.940
204-1PDL-614	1/4	14MM x 1.5	8	17	1.811	.901
204-1PDL-616	1/4	16MM x 1.5	10	19	1.831	.921
206-1PDL-616	3/8	16MM x 1.5	10	19	1.831	.921
206-1PDL-618	3/8	18MM x 1.5	12	22	1.870	.960
206-1PDL-622	3/8	22MM x 1.5	15	27	2.008	1.098
208-1PDL-622	1/2	22MM x 1.5	15	27	2.244	1.084

METRIC SWIVEL FEMALE STEM DIN 20078 LIGHT 45° BENT TUBE W/O-RING

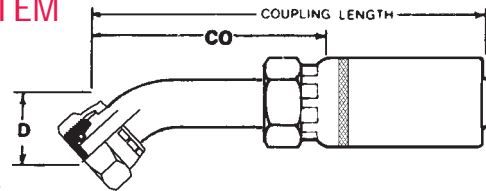

Part Number	Hose I.D.	Thread	DIN Tube O.D.(mm)	Nut Hex (mm)	-D-Drop	Fitting Length	-CO-Cutoff
204-1PDL-614 45	1/4	14MM x 1.5	8	17	.748	2.402	1.492
204-1PDL-616 45	1/4	16MM x 1.5	10	19	.827	2.638	1.728
206-1PDL-616 45	3/8	16MM x 1.5	10	19	.846	2.677	1.767
206-1PDL-618 45	3/8	18MM x 1.5	12	22	.984	3.189	2.029
208-1PDL-622 45	1/2	22MM x 1.5	15	27			



SAE 100R12 Non-Skive
SAE 100R13 Skive

1W

One-Piece
British Standard
and Metric Fittings

METRIC
SWIVEL FEMALE
W/ O-RING
DIN LIGHT
STRAIGHT

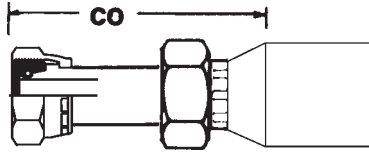

Part Number	Hose I.D.	Thread	DIN Tube O.D.(mm)	Fitting Length	-CO-Cutoff
612-1WDL-626	3/4	26MM x 1.5	18	2.78	1.08
612-1WDL-630	3/4	30MM x 2	22	2.84	1.14
616-1WDL-636	1	36MM x 2	28	3.19	1.24
620-1WDL-645	1-1/4	45MM x 2	35	3.84	1.46

METRIC
SWIVEL FEMALE
W/ O-RING AND
UNIV CONE SEAT
DIN HEAVY
STRAIGHT

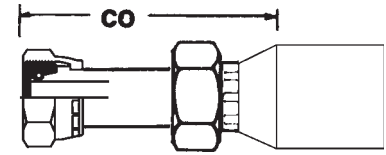

Part Number	Hose I.D.	Thread	DIN Tube O.D.(mm)	Fitting Length	-CO-Cutoff
612-1WDH-630	3/4	30MM x 2	20	3.07	1.37
616-1WDH-636	1	36MM x 2	25	3.29	1.34
612-1WDH-636	3/4	36MM x 2	25	3.29	1.34
616-1WDH-642	1	42MM x 2	30	3.54	1.59
620-1WDH-652	1-1/4	52MM x 2	38	4.15	1.78

METRIC
SWIVEL FEMALE
W/ O-RING
DIN LIGHT
45°

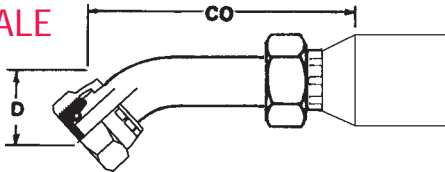

Part Number	Hose I.D.	Thread	DIN Tube O.D.(mm)	-D-Drop	Fitting Length	-CO-Cutoff
612-1WDL-630	45 3/4	30MM x 2	22	.97	4.10	2.40
616-1WDL-636	45 1	36MM x 2	28	1.10	4.72	2.77
620-1WDL-645	45 1-1/4	45MM x 2	35	1.71	6.46	4.08

METRIC
SWIVEL FEMALE
W/ O-RING AND
UNIV CONE SEAT
DIN HEAVY
45°

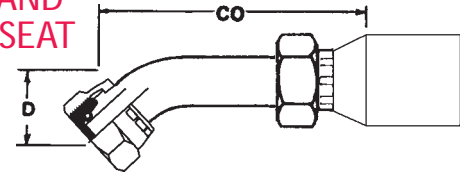

Part Number	Hose I.D.	Thread	DIN Tube O.D.(mm)	-D-Drop	Fitting Length	-CO-Cutoff
612-1WDH-636	45 3/4	36MM x 2	25	1.12	4.25	2.55
616-1WDH-642	45 1	42MM x 2	30	1.28	4.88	2.93
620-1WDH-652	45 1-1/4	52MM x 2	38	1.77	6.52	4.14

METRIC
SWIVEL FEMALE
W/ O-RING
DIN LIGHT
90°

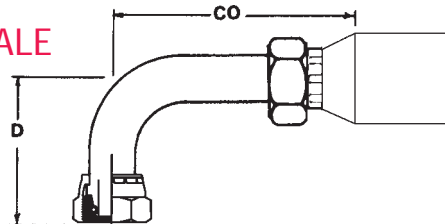

Part Number	Hose I.D.	Thread	DIN Tube O.D.(mm)	-D-Drop	Fitting Length	-CO-Cutoff
612-1WDL-630	90 3/4	30MM x 2	22	2.07	3.82	2.12
616-1WDL-636	90 1	36MM x 2	28	2.40	4.45	2.50
620-1WDL-645	90 1-1/4	45MM x 2	35	3.68	5.91	3.53

METRIC
SWIVEL FEMALE
W/ O-RING AND
UNIV CONE SEAT
DIN HEAVY
90°

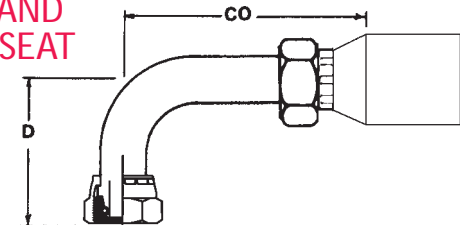

Part Number	Hose I.D.	Thread	DIN Tube O.D.(mm)	-D-Drop	Fitting Length	-CO-Cutoff
612-1WDH-636	90 3/4	36MM x 2	25	2.28	3.82	2.12
616-1WDH-642	90 1	42MM x 2	30	2.64	4.45	2.50
620-1WDH-652	90 1-1/4	52MM x 2	38	3.64	5.91	3.53