

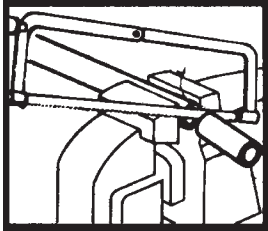

Reusable Hose Fittings — Non-Mandrel Type for SAE 100R5 Hose — DOT FMVSS 106 TYPE AII

ASSEMBLY INSTRUCTIONS NON-MANDREL TYPE FITTINGS — SAE 100R5 HOSE



1. Cut hose square to desired length using fine-tooth hacksaw or cut-off wheel.

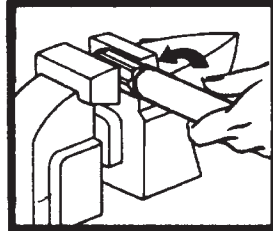

2. Hold socket securely with wrench or place in vise, if available, and screw hose in counter-clockwise using body weight to start threading.

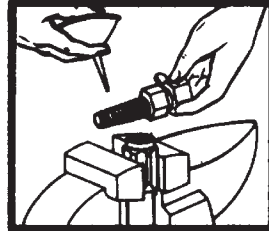

3. Oil inside of hose and socket threads. This lubrication makes assembly much easier.

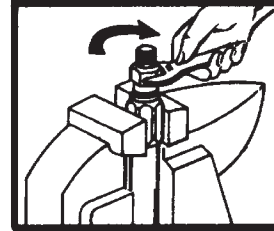

4. Screw nipple into socket using wrench on hex of nipple.

NPTF SOLID MALE REUSABLE NON-MANDREL FOR SAE 100R5 HOSE

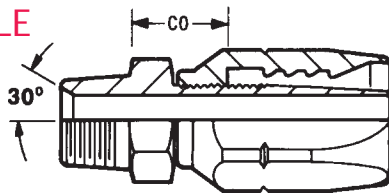

Part Number	Hose I.D.	Thread	Hex	Stem I.D.	Fitting Length	-CO-Cutoff
204-5RU-102	3/16	1/8 - 27	9/16	.125	1.672	.922
204-5RU-104	3/16	1/4 - 18	9/16	.125	1.860	1.110
205-5RU-104	1/4	1/4 - 18	9/16	.172	1.969	1.187
206-5RU-104	5/16	1/4 - 18	9/16	.234	2.172	1.234
206-5RU-106	5/16	3/8 - 18	11/16	.234	2.203	1.266
208-5RU-106	13/32	3/8 - 18	11/16	.344	2.485	1.328
208-5RU-108	13/32	1/2 - 14	7/8	.344	2.781	1.562
210-5RU-108	1/2	1/2 - 14	7/8	.453	2.860	1.594
210-5RU-112	1/2	3/4 - 14	1-1/16	.453	2.860	1.656
212-5RU-112	5/8	3/4 - 14	1-1/16	.562	3.203	1.672
220-5RU-120	1-1/8	1-1/4 - 11-1/2				

JIC 37° SOLID MALE REUSABLE NON-MANDREL FOR SAE 100R5 HOSE

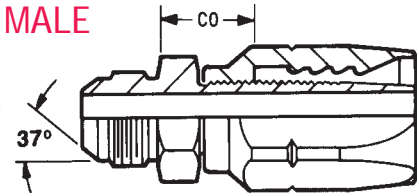

Part Number	Hose I.D.	Thread	Hex	Stem I.D.	Fitting Length	-CO-Cutoff
204-5RU-504	3/16	7/16 - 20	1/2	.125	1.844	1.094
205-5RU-505	1/4	1/2 - 20	9/16	.172	1.953	1.172
206-5RU-506	5/16	9/16 - 18	5/8	.234	2.125	1.219
208-5RU-508	13/32	3/4 - 16	13/16	.360	2.562	1.312
210-5RU-510	1/2	7/8 - 14	15/16	.453	2.891	1.500
212-5RU-512	5/8	1-1/16 - 12	1-1/8	.578	3.344	1.781
216-5RU-516	7/8	1-5/16 - 12	1-3/8	.812	2.937	1.687

SAE 45° SWIVEL FEMALE REUSABLE NON-MANDREL FOR SAE 100R5 HOSE

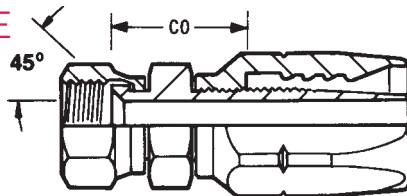

Part Number	Hose I.D.	Thread	Stem Hex	Nut Hex	Stem I.D.	Fitting Length	-CO-Cutoff
206-5RU-406	5/16	5/8 - 18	3/4	3/4	.234	2.344	1.437
212-5RU-412	5/8	1-1/16 - 14	1-1/4	1-1/4	.562	3.500	1.922

ORB SOLID MALE REUSABLE NON-MANDREL FOR SAE 100R5 HOSE

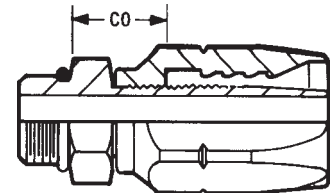

Part Number	Hose I.D.	Thread	Hex	Stem I.D.	Fitting Length	-CO-Cutoff
204-5RU-704	3/16	7/16 - 20	9/16	.125	1.641	.891
205-5RU-705	1/4	1/2 - 20	5/8	.172	1.750	.969
206-5RU-706	5/16	9/16 - 18	11/16	.234	1.937	1.031
208-5RU-708	13/32	3/4 - 16	7/8	.344	2.344	1.094
210-5RU-710	1/2	7/8 - 14	1	.453	2.625	1.234
212-5RU-712	5/8	1-1/16 - 12	1-1/4	.562	3.094	1.531
216-5RU-716	7/8	1-5/16 - 12	1-1/2	.812	2.656	1.391



Reusable Hose Fittings — Non-Mandrel Type for SAE 100R5 Hose

JIC 37°
SWIVEL FEMALE
REUSABLE
NON-MANDREL
FOR SAE
100R5 HOSE

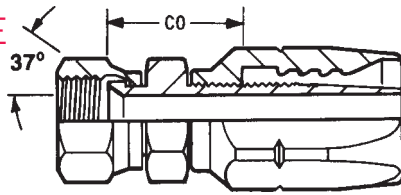

Part Number	Hose I.D.	Thread	Stem Hex	Nut Hex	Stem I.D.	Fitting Length	-CO- Cutoff
204-5RU-604	3/16	7/16 - 20	9/16	9/16	.125	1.937	1.187
205-5RU-605	1/4	1/2 - 20	5/8	5/8	.172	2.078	1.297
206-5RU-606	5/16	9/16 - 18	11/16	11/16	.234	2.312	1.406
208-5RU-608	13/32	3/4 - 16	7/8	7/8	.344	2.844	1.578
210-5RU-610	1/2	7/8 - 14	1	1	.453	3.062	1.672
212-5RU-612	5/8	1-1/16 - 12	1-1/4	1-1/4	.562	3.500	1.922
216-5RU-616	7/8	1-5/16 - 12	1-1/2	1-1/2	.812	3.187	1.922
220-5RU-620	1-1/8	1-5/8 - 12	2	2	1.047	3.375	2.031
224-5RU-624	1-3/8	1-7/8 - 12	2-1/4	2-1/4	1.281	3.656	2.244
232-5RU-632	1-13/16	2-1/2 - 12	2-7/8	2-7/8	1.750	4.437	2.578

JIC 37°
SWIVEL FEMALE
REUSABLE
90° BENT TUBE
MEDIUM DROP
NON-MANDREL
FOR SAE 100R5 HOSE

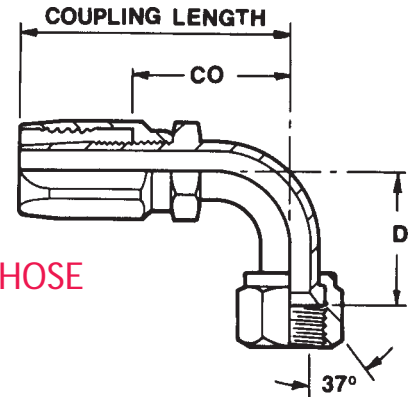

Part Number	Hose I.D.	Thread	Nut Hex	-D- Drop	Fitting Length	-CO- Cutoff
204-5RU-664	3/16	7/16 - 20	9/16	.690	1.750	1.000
205-5RU-665	1/4	1/2 - 20	5/8	.760	1.970	1.190
206-5RU-666	5/16	9/16 - 18	11/16	.840	2.120	1.230
208-5RU-668	13/32	3/4 - 16	7/8	1.090	2.750	1.610
210-5RU-670	1/2	7/8 - 14	1	1.230	2.940	1.660
212-5RU-672	5/8	1-1/16 - 12	1-1/4	1.810	3.750	2.170
216-5RU-676	7/8	1-5/16 - 12	1-1/2	2.140	3.550	2.280

JIC 37°
SWIVEL FEMALE
REUSABLE
45° BENT TUBE
MEDIUM DROP
NON-MANDREL
FOR SAE 100R5 HOSE

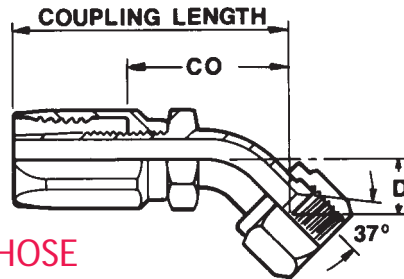

Part Number	Hose I.D.	Thread	Nut Hex	-D- Drop	Fitting Length	-CO- Cutoff
204-5RU-684	3/16	7/16 - 20	9/16	.330	1.840	1.110
205-5RU-685	1/4	1/2 - 20	5/8	.360	1.060	1.280
206-5RU-686	5/16	9/16 - 18	11/16	.390	2.230	1.330
208-5RU-688	13/32	3/4 - 16	7/8	.550	2.980	1.840
210-5RU-690	1/2	7/8 - 14	1	.630	3.230	1.950
212-5RU-692	5/8	1-1/16 - 12	1-1/4	.770	3.780	2.220
216-5RU-696	7/8	1-5/16 - 12	1-1/2	.890	3.560	2.230

JIC 37°
SWIVEL FEMALE
REUSABLE
90° BENT TUBE
LONG DROP
NON-MANDREL
FOR SAE 100R5 HOSE

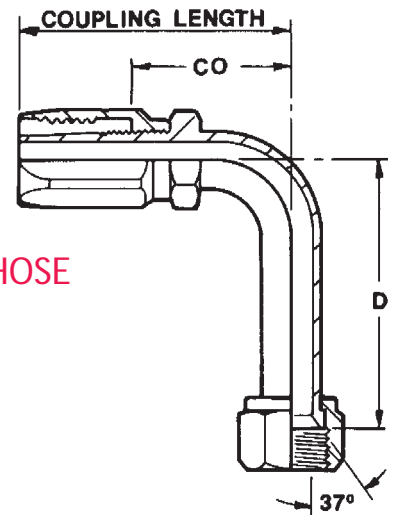

Part Number	Hose I.D.	Thread	Nut Hex	-D- Drop	Fitting Length	-CO- Cutoff
204-5RL-664	3/16	7/16 - 20	9/16	1.800	1.750	1.000
205-5RL-665	1/4	1/2 - 20	5/8	1.780	1.970	1.190
206-5RL-666	5/16	9/16 - 18	11/16	2.190	2.120	1.230
208-5RL-668	13/32	3/4 - 16	7/8	2.440	2.750	1.610
210-5RL-670	1/2	7/8 - 14	1	2.560	2.940	1.660
212-5RL-672	5/8	1-1/16 - 12	1-1/4	3.730	3.750	2.170
216-5RL-676	7/8	1-5/16 - 12	1-1/2	4.330	3.550	2.280



Reusable Hose Fittings Skive Type for SAE 100R2A Hose

ASSEMBLY INSTRUCTIONS SKIVE TYPE FITTINGS-SAE 100R2A

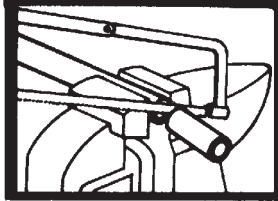

1. Cut hose to desired length using fine tooth hacksaw or cut-off wheel.

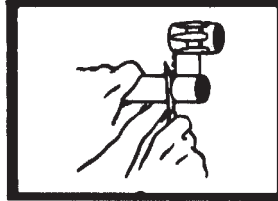

2. Determine length of hose to be reduced to socket diameter and score with sharp knife.

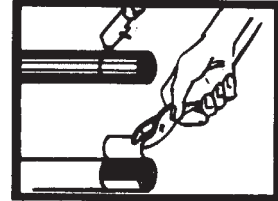

3. After slitting the rubber cover, twist off with pliers. If any particles of rubber remain, remove with wire brush.

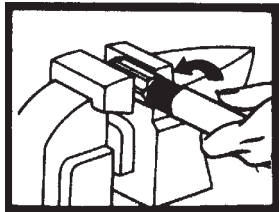

4. Place socket in vise and screw hose in counter-clockwise, using body weight against hose to start threading. Tighten until hose bottoms, then back off 1/4 turn.

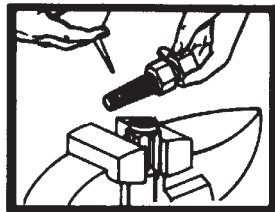

5. Oil inside of hose and nipple threads.

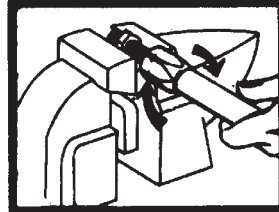

6. Place nipple in vise. Push and turn socket, with hose inserted, clockwise on to stem until threads engage.

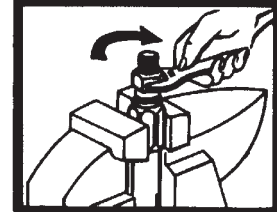

7. Screw nipple into socket, using wrench on hex of nipple. After assembled, blow out with air pressure to remove any loose particles and inspect.

NOTE: Some fitting sockets have annular grooves: in this case push down on hose while turning hose into socket, using an alternating motion of a quarter turn in each direction.

NPTF SOLID MALE REUSABLE SKIVE TYPE FOR SAE 100R2A HOSE

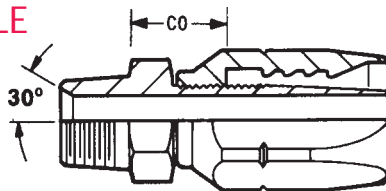

JIC 37° SOLID MALE REUSABLE SKIVE TYPE FOR SAE 100R2A HOSE

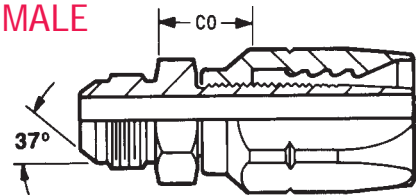

Part Number	Hose I.D.	Thread	Hex	Stem I.D.	Fitting Length	-CO- Cutoff
204-2RU-102	1/4	1/8-27	9/16	.172	2.344	1.125
204-2RU-104	1/4	1/4-18	9/16	.172	2.562	1.344
206-2RU-104	3/8	1/4-18	11/16	.297	2.781	1.312
206-2RU-106	3/8	3/8-18	11/16	.297	2.781	1.312
208-2RU-106	1/2	3/8-18	7/8	.375	2.937	1.375
208-2RU-108	1/2	1/2-14	7/8	.375	3.125	1.562
212-2RU-112	3/4	3/4-14	1-1/16	.594	3.656	1.750
216-2RU-116	1	1-11/2	1-3/8	.812	4.344	2.281
220-2RU-120	1-1/4	1 1/2-11 1/2	1-3/4	1.047	4.937	2.594
224-2RU-124	1-1/2	1 1/2-11 1/2	2	1.281	5.000	2.687
232-2RU-132	2	2-11 1/2	2-1/2	1.750	5.344	2.844

Part Number	Hose I.D.	Thread	Hex	Stem I.D.	Fitting Length	-CO- Cutoff
204-2RU-504	1/4	7/16 - 20	9/16	.172	2.531	1.297
204-2RU-505	1/4	1/2 - 20	9/16	.172	2.531	1.297
204-2RU-506	1/4	9/16 - 18	9/16	.172	2.547	1.312
206-2RU-506	3/8	9/16 - 18	11/16	.297	2.750	1.281
206-2RU-508	3/8	3/4 - 16	7/8	.297	2.891	1.437
208-2RU-508	1/2	3/4 - 16	7/8	.375	3.031	1.469
208-2RU-510	1/2	7/8 - 14	7/8	.375	3.141	1.594
212-2RU-512	3/4	1-1/16 - 12	1-18	.594	3.781	1.875
216-2RU-516	1	1-5/16 - 12	1-3/8	.812	4.344	2.281
220-2RU-520	1-1/4	1-5/8 - 12	1-3/4	1.047	4.875	2.562
224-2RU-524	1-1/2	1-7/8 - 12	2	1.281	5.128	2.812



Reusable Hose Fittings

Skive Type for SAE 100R2A Hose

JIC 37° SWIVEL FEMALE
REUSEABLE-SKIVE TYPE
FOR SAE
100R2A HOSE

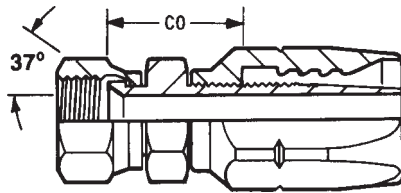

Part Number	Hose I.D.	Thread	Stem Hex	Nut Hex	Stem I.D.	Fitting Length	-CO- Cutoff
204-2RU-604	1/4	7/16-20	9/16	9/16	.172	2.625	1.375
204-2RU-605	1/4	1/2-20	5/8	5/8	.172	2.672	1.422
204-2RU-606	1/4	9/16-18	11/16	11/16	.172	2.781	1.547
206-2RU-606	3/8	9/16-18	11/16	11/16	.297	2.953	1.500
206-2RU-608	3/8	3/4-16	7/8	7/8	.297	3.094	1.625
208-2RU-608	1/2	3/4-16	7/8	7/8	.375	3.234	1.672
208-2RU-610	1/2	7/8-14	1	1	.375	3.328	1.766
212-2RU-612	3/4	1-1/16-12	1-1/4	1-1/4	.594	3.891	2.000
212-2RU-614	3/4	1-3/16-12	1-3/8	1-3/8	.594	3.969	2.078
216-2RU-616	1	1-5/16-12	1-1/2	1-1/2	.812	4.453	2.437
220-2RU-620	1-1/4	1-5/8-12	2	2	1.047	5.141	2.781
220-2RU-624	1-1/2	1-7/8-12	2-1/4	2-1/4	1.281	.219	2.969
232-2RU-632	2	2-1/2-12	2-7/8	2-7/8	1.750	5.906	3.437

O-RING SEAL-TUBE END MALE
REUSEABLE-SKIVE TYPE
FOR SAE
100R2A HOSE

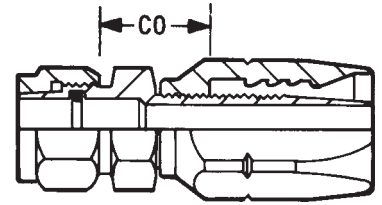

Part Number	Hose I.D.	Tube Size	Stem Hex	Stem I.D.	Fitting Length	-CO- Cutoff
204-ORS-04	1/4	1/4	9/16	.172	2.672	1.437
206-ORS-06	3/8	3/8	11/16	.297	2.984	1.531
206-ORS-08	3/8	1/2	7/8	.297	2.234	1.781
208-ORS-08	1/2	1/2	7/8	.375	3.375	1.812
208-ORS-10	1/2	5/8	1	.375	3.531	1.937
212-ORS-12	3/4	3/4	1-1/8	.594	4.125	2.219
216-ORS-16	1	1	1-1/2	.812	4.750	2.719
220-ORS-20	1-1/4	1-1/4	1-3/4	1.047	5.578	3.250
224-ORS-24	1-1/2	1-1/2	2	1.281	5.844	3.531

ORB SOLID MALE
REUSEABLE
SKIVE TYPE
FOR SAE
100R2A HOSE

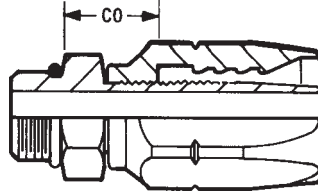

Part Number	Hose I.D.	Thread	Hex	Stem I.D.	Fitting Length	-CO- Cutoff
204-2RU-704	1/4	7/16-20	9/16	.172	2.344	1.109
206-2RU-706	3/8	9/16-18	11/16	.297	2.609	1.156
206-2RU-708	3/8	3/4-16	7/8	.297	2.687	1.219
208-2RU-708	1/2	3/4-16	7/8	.375	2.844	1.297
208-2RU-710	1/2	7/8-14	1	.375	2.937	1.391
212-2RU-712	3/4	1-1/16-12	1-1/4	.594	3.500	1.594
216-2RU-716	1	1-5/16-12	1-1/2	.812	3.953	1.906



One-Piece Fittings for P.T.F.E. Hose

NPTF SOLID MALE

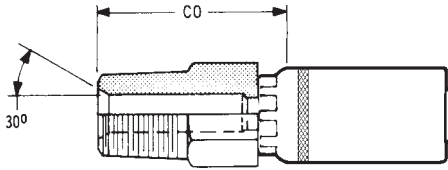

Part Number	Hose I.D.	Thread	Hex	Fitting Length	-CO-Cutoff
204-1PTF-102	3/16	1/8-27	1/2		
204-1PTF-104	3/16	1/4-18	9/16		
205-1PTF-104	1/4	1/4-18	9/16		
206-1PTF-104	5/16	1/4-18	9/16		
206-1PTF-106	5/16	3/8-18	11/16		
207-1PTF-106	3/8	3/8-18	11/16		
208-1PTF-106	13/32	3/8-18	11/16	1.971	1.061
208-1PTF-108	13/32	1/2-14	7/8		
210-1PTF-108	1/2	1/2-14	7/8		
212-1PTF-112	5/8	3/4-14	1-1/16	2.534	1.374
• 214-1PTF-112	3/4	3/4-14	1-1/16		
216-1PTF-116	7/8	1-11-1/2	1-3/8		
• 218-1PTF-116	1	1-11-1/2	1-3/8		

SAE 45° SWIVEL FEMALE STAINLESS STEEL TYPE 304

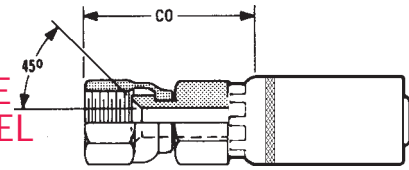

Part Number	Hose I.D.	Thread	Hex	Fitting Length	-CO-Cutoff
• 206-1PTFSS-406	5/16	5/8-18			

JIC 37° SWIVEL MALE

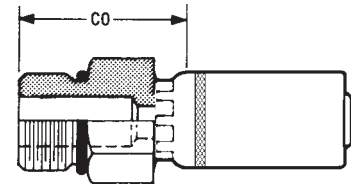

Part Number	Hose I.D.	Thread	Hex	Fitting Length	-CO-Cutoff
• 212-1PTF-510	5/8	7/8-14			

NPTF SWIVEL MALE

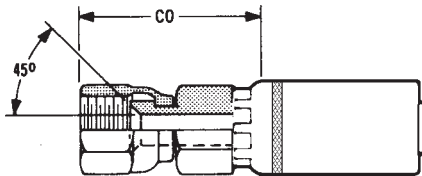

Part Number	Hose I.D.	Thread	Hex	Fitting Length	-CO-Cutoff
• 206-1PTF-206	5/16	3/8-18			
• 207-1PTF-206	3/8	3/8-18			
• 210-1PTF-208	1/2	1/2-14			

JIC 37° SWIVEL FEMALE

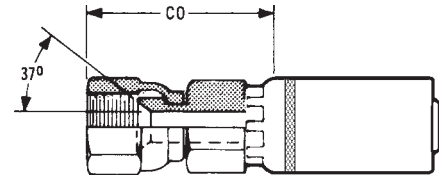

Part Number	Hose I.D.	Thread	Stem Hex	Nut Hex	Fitting Length	-CO-Cutoff
• 203-1PTF-603	1/8	3/8-24				
• 204-1PTF-603	3/16	3/8-24				
204-1PTF-604	3/16	7/16-20	1/2	9/16	1.885	.975
205-1PTF-604	1/4	7/16-20	1/2	9/16	1.995	1.085
205-1PTF-605	1/4	1/2-20	5/8	11/16	2.050	1.140
• 205-1PTF-606	1/4	9/16-18				
206-1PTF-605	5/16	1/2-20	5/8	11/16	2.050	1.140
206-1PTF-606	5/16	9/16-18	5/8	3/4	2.035	1.125
207-1PTF-606	3/8	9/16-18	5/8	3/4	2.035	1.125
208-1PTF-608	13/32	3/4-16	11/16	7/8	2.165	1.255
• 208-1PTF-610	13/32	7/8-14				
210-1PTF-608	1/2	3/4-16	13/16	7/8	2.212	1.302
210-1PTF-610	1/2	7/8-14	13/16	1-1/16	2.280	1.370
212-1PTF-610	5/8	7/8-14	1	1-1/16	2.580	1.420
212-1PTF-612	5/8	1-1/16-12	1	1-1/4	2.655	1.495
214-1PTF-612	3/4	1-1/16-12	1	1-1/4	2.655	1.495
216-1PTF-612	7/8	1-1/16-12	1-1/16	1-1/4	2.815	1.565
216-1PTF-616	7/8	1-5/16-12	1-1/4	1-1/2	2.910	1.660
218-1PTF-616	1	1-5/16-12	1-1/4	1-1/2	2.910	1.660
220-1PTF-620	1-1/8	1-5/8-12	1-1/2	2	3.175	1.825

SAE SOLID MALE

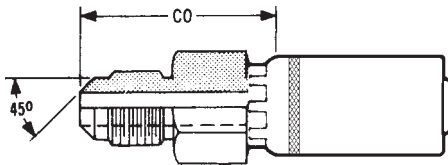

Part Number	Hose I.D.	Thread	Hex	Fitting Length	-CO-Cutoff
206-1PTF-305	5/16	1/2-20	5/8	1.939	1.374

SAE 45° SWIVEL FEMALE

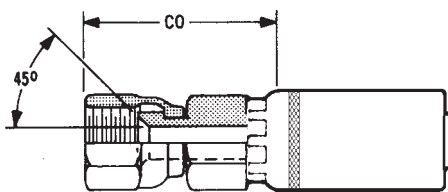

Part Number	Hose I.D.	Thread	Stem Hex	Nut Hex	Fitting Length	-CO-Cutoff
• 204-1PTF-403	3/16	3/8-24				
• 205-1PTF-404	1/4	7/16-20				
206-1PTF-405	5/16	1/2-20	5/8	11/16	2.035	1.115
206-1PTF-406	5/16	5/8-18	5/8	3/4	2.115	1.195
207-1PTF-406	3/8	5/8-18	5/8	3/4	2.115	1.195
210-1PTF-410	1/2	7/8-14	13/16	1-1/16	2.235	1.385

JIC 37° SWIVEL FEMALE STAINLESS STEEL TYPE 303/304

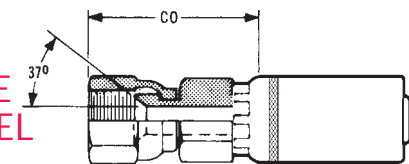

Part Number	Hose I.D.	Thread	Hex	Fitting Length	-CO-Cutoff
• 205-1PTFSS-604	1/4	7/16-20			
• 207-1PTFSS-606	3/8	9/16-18			

• Indicates change or new product

One-Piece Fittings for P.T.F.E. Hose



ORB SOLID MALE

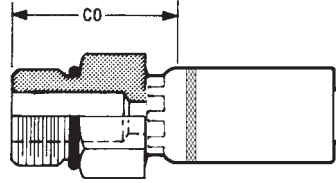

Part Number	Hose I.D.	Thread	Hex	Fitting Length	-CO-Cutoff
• 206-1PTF-706	5/16	9/16-18			

NPTF SOLID FEMALE

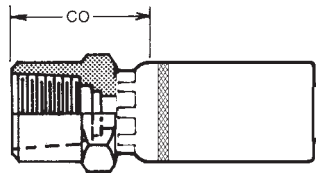

Part Number	Hose I.D.	Thread	Hex	Fitting Length	-CO-Cutoff
• 205-1PTF-904	1/4	1/4-18			

SAE 45° SOLID FEMALE INVERTED FLARE

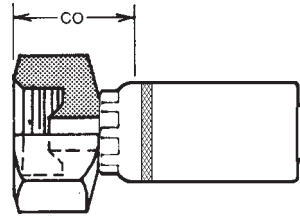

Part Number	Hose I.D.	Thread	Hex	Fitting Length	-CO-Cutoff
• 206-1PTF-905 IF	5/16	1/2-20			
• 206-1PTF-906 IF	5/16	5/8-18			

NPSM SWIVEL FEMALE

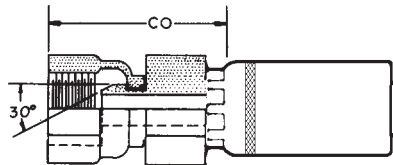

Part Number	Hose I.D.	Thread	Hex	Fitting Length	-CO-Cutoff
• 205-1PTF-FPX	1/4	1/4-18			

SAE 45° SWIVEL FEMALE 45° BENT TUBE SHORT DROP

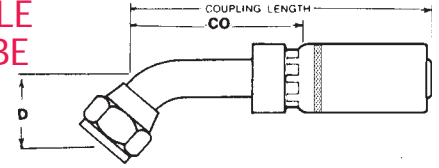

Part Number	Hose I.D.	Thread	Nut Hex	-D-Drop	Fitting Length	-CO-Cutoff
• 204-1PTFS-483	3/16	3/8-24				
• 205-1PTFS-484	1/4	7/16-20				
• 206-1PTFS-486	5/16	5/8-18	3/4	.410	2.925	2.015

SAE 45° SWIVEL FEMALE 90° BENT TUBE SHORT DROP

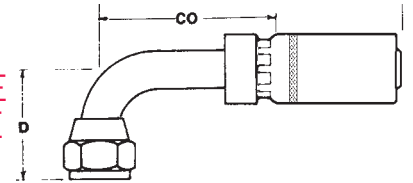

Part Number	Hose I.D.	Thread	Nut Hex	-D-Drop	Fitting Length	-CO-Cutoff
• 204-1PTFS-463	3/16	3/8-24				
• 205-1PTFS-464	1/4	7/16-20				
• 206-1PTFS-466	5/16	5/8-18	3/4	.850	2.575	1.665

JIC 37° SWIVEL FEMALE 45° BENT TUBE SHORT DROP

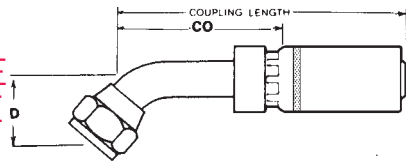

Part Number	Hose I.D.	Thread	Nut Hex	-D-Drop	Fitting Length	-CO-Cutoff
• 205-1PTFS-684	1/4	7/16-20				
• 206-1PTFS-686	5/16	9/16-18	11/16			2.015
• 207-1PTFS-686	3/8	9/16-18	11/16	.410	2.925	2.015
• 216-1PTFS-696	7/8	1-5/16-12	1-1/2	.890	4.555	3.300
• 218-1PTFS-696	1	1-5/16-12	1-1/2			3.300

• Indicates change or new product